

---

---

---

# *Owner's Manual for Dentalaire Prestige Dental Stations*



**DENTALAIRE** 

Toll Free (800) 866-6881  
Fax (714) 540-9947  
[www.Dentalaire.com](http://www.Dentalaire.com)  
17742 Mitchell North, Suite B, Irvine CA 92614

**DENTALAIRE** 









## NOTES



### Attaching Handpiece

**CAUTION:** Do not operate any handpiece without a bur, prophyl angle, contra angle or bur blank tightened securely in place. Permanent Turbine/Chuck damage will result!

**Step 11:** Next open up the bag containing the parts to your piezo scaler. There are two blue rubber sleeves, to install simply slip over the handpiece. You have two scaler tips that come with your scaler. One is the **# 32 tip**, which is your flat or wide tip. The other tip is the **# 39 tip**, which is your universal tip. These tips are screwed into place using one of the two tip wrenches included. Now you gently screw the dental tip into place, finger tight at first then snug tight with one of the tip wrenches. DentaLaire also carries a true Perio Tip for subgingival scaling. It is a little longer and thinner than the Universal Tip (**# 39 tip**). DTP00786 is the order number for the Special/Perio Tip (**# 33 tip**).

Lubricating Handpiece Attaching Handpiece Dental Inserts.

**Step 12:** Please make sure the water switch is on (only certain units will have an on/off switch) and the water flow control knob is open. Counterclockwise will increase water flow (to the left), clockwise will decrease water flow and all the way clockwise will shut it off (turning all the way to the right). The little button on the foot control activates the piezo electric scaler only. A good starting point for the scaler intensity is usually around 50% (this is the knob you can turn from 10-100). The intensity can be increased as needed for each different dental. If you do a large number of dentals, e.g. 15-20 a day, 5 days a week, you could wear these tips out in 3-4 months.

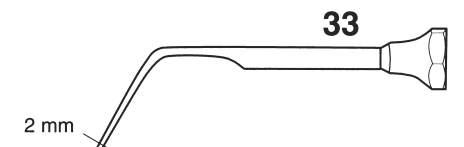
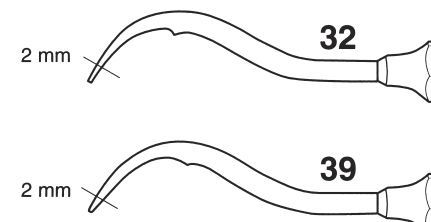

### Dental Inserts

#### IMPORTANT NOTE

#### After Treatment:

1. Screw off tip, counter-clockwise, with tip wrench.
2. Squeeze the Ergo Grip gently at the top and at the same time slide it off the handpiece. Do not squeeze too hard at the Ergo Grip as this can make the removal difficult.
3. Clean and sterilize the equipment according to the general cleaning procedure.

**CAUTION:** Never, ever use worn out tips. This will result in severe damage to the handpiece. Please routinely check the tips by using the chart provided, which shows expected tip wear. Remember, if you are having to constantly adjust the power setting up, the tips are probably worn and need to be replaced.

Enjoy your new dental unit. Please call us at (800)866-6881 if you have any questions. We are here to help in any way we can.

Please note: If you have any kind of damage, please notify Dentalaire right away. We have a two week window where we can make a claim if there are any damages to the dental station. After that, if you get a dental station from us, have it for a month, open it up and then find damages, we cannot get any kind of credit from our shipper. This makes it very difficult for all parties involved.

Thanks for your help in this matter.

## SELECTION OF HANDPIECES

Your dental station comes with a high-speed and a Low-speed handpiece. The high-speed is for drilling and sectioning of the teeth. The low speed is used mainly for polishing. It also can have an air scaler or a piezo scaler, which is used to scale (clean) the teeth.

## OPERATION OF HANDPIECES

High-Speed Handpiece operates at pressures of 38 to 40 PSI and attains a speed of 350,000 to 400,000 RPM. The water mist helps to keep the handpiece motor and bur cool, as well as the patient's tooth cool while doing restorations, cutting or rotary prophylaxis scaling procedures. Constant preventive maintenance is essential in caring for handpieces. If they are not properly cleaned and lubricated, abrasives such as finely ground tooth, metal will cause excessive wear and undue vibration.

To insert or remove burs from the high-speed drill hand piece on units that have a push button bur changer, to insert the bur simply push your thumb on the back cap of the high-speed handpiece hand piece enough to feel a solid click to engage and open the chuck. Once you have pushed hard enough to feel a solid click, then you insert the bur all the way in as far as you can. To take the bur out repeat the above step and then pull out the bur. When inserting and removing burs from the drill on standard non-push-button handpiece, use the bur tool by holding it between the thumb and forefinger. Slide the bur tool over the head of the handpiece. Pull the wrench knob away from the head, then push the knob back to engage the chuck. The square tip of the wrench must fit into the square hole inside of the handpiece head (this is the chuck). To remove the bur, rotate the wrench one full turn Counter Clockwise until the bur is free. To tighten, rotate the wrench one full turn Clockwise until the bur is secure. Never overtighten the bur, as serious damage can result to the chuck and bur tool.

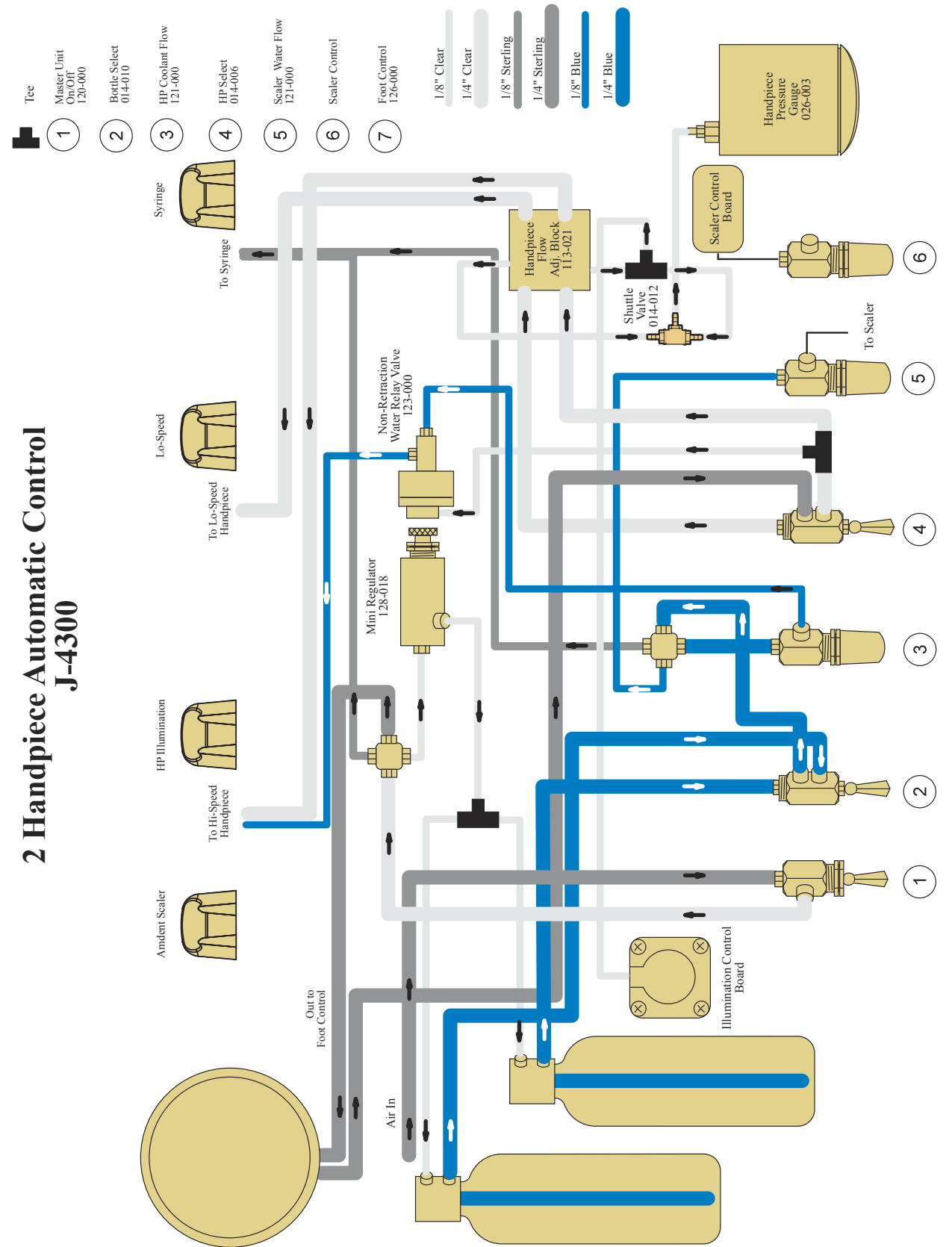

*Non-Retraction Water Relay Valve*

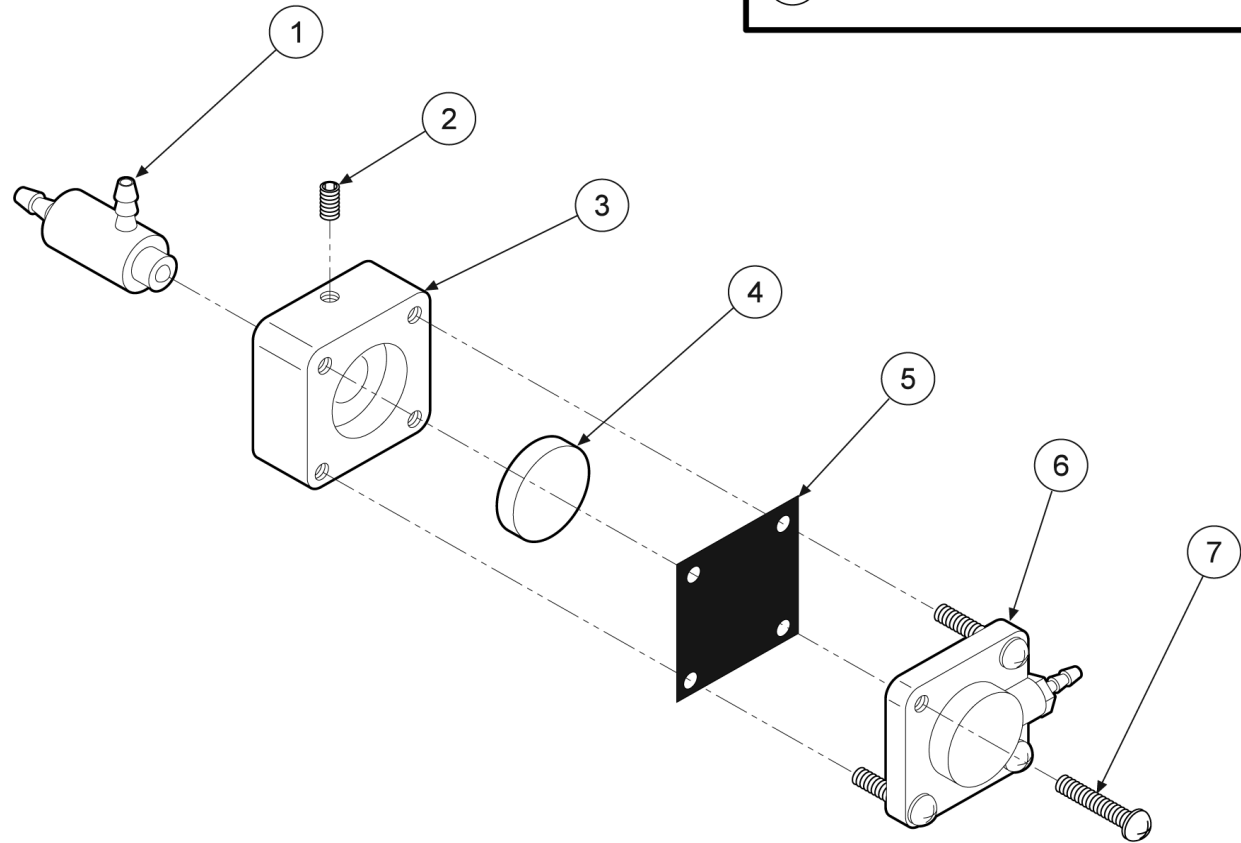
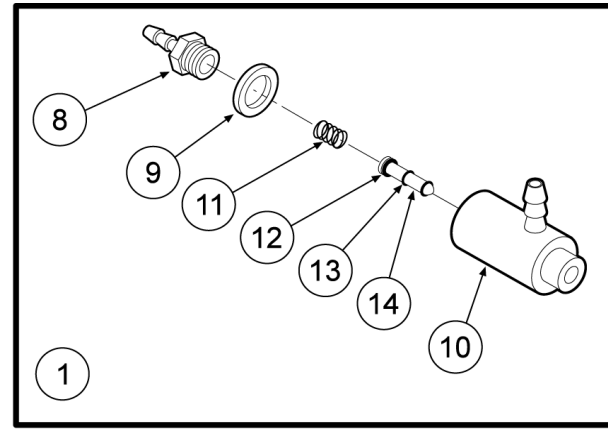

*Push Button Bur*



*Bur Tool Changing*

*If you do not put the bur in all the way it will damage the chuck. You will then need to purchase a new turbine for your high-speed handpiece.*

**Slow-Speed Handpiece** operates at pressures of 32 to 40 PSI and generates speeds from a crawl to 5500 RPM depending on the pressure applied to the foot control. The slow speed should be placed on the right side of the delivery system (dry side), as no coolant is needed for the slow speed procedures.

*As with the high-speed handpiece, always read and follow manufacturer's instructions for operation, lubrication, cleaning, and sterilization for the slow speed motor and attachments.*

*Slow-Speed Handpiece  
Nose Portion Swivels 360° To Reduce Hand Fatigue*

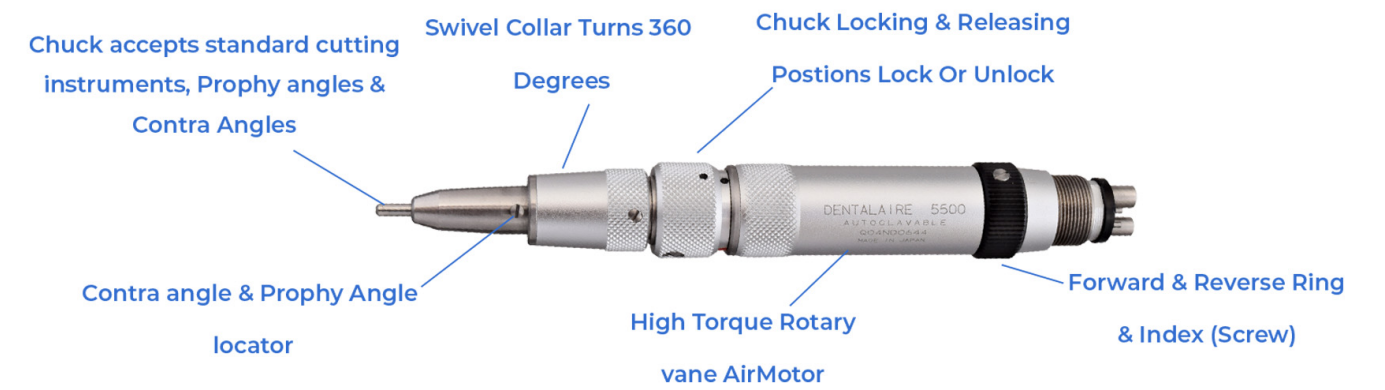

To attach prophy angles, contra angles, cutting wheels or handpiece burs to the handpiece, simply turn lock ring to unlock position slide in prophy angle then turn to lock position. Please note: If the prophy angle ever gets stuck, once you have removed it you can spray Lubricant into the bottom of the prophy angle. This should help resolve the problem.

**CAUTION:** Do not run slow-speed unless an angle or bur is installed as serious chuck damage will result.

### CLEANING OF HIGH-SPEED AND SLOW-SPEED HANDPIECES

Before cleaning procedures the bur must be removed from the handpiece. The handpiece must be cleaned with a brush or wiped with alcohol after each patient.

Never use any type of chemicals to clean these handpieces. This includes Nolvasan, Roccal D, chemicals used in Ultrasonic cleaners. These cleaners will ruin the turbines and bearings in the handpieces.

### STERILIZATION OF HIGH AND SLOW-SPEED HANDPIECES

1. The handpiece must be sterilized by autoclave for 15 minutes at 135°C (275°F).  
Do not exceed 275°F when autoclaving.
2. Only use non chlorine products, and no chemical solutions.
3. Do not sterilize the high-speed handpiece with the bur inserted. Also, never sterilize the low speed with the prophy angle attached.
4. Always lubricate the handpieces before you autoclave them, then once handpiece has returned to room temperature you should lubricate it again.

### REPAIR AND REPLACING THE HIGH-SPEED CARTRIDGE

Only use the original replacement turbines, for total assurance of quality control and product life. The cartridge is a fragile instrument. Please call our service department if you have questions or need help in replacing this part.

- DA400RCA – Push Button Turbine w/Cap
- DANSK-A485 – Push Button Turbine Only
- DA400RC – Standard Type Turbine

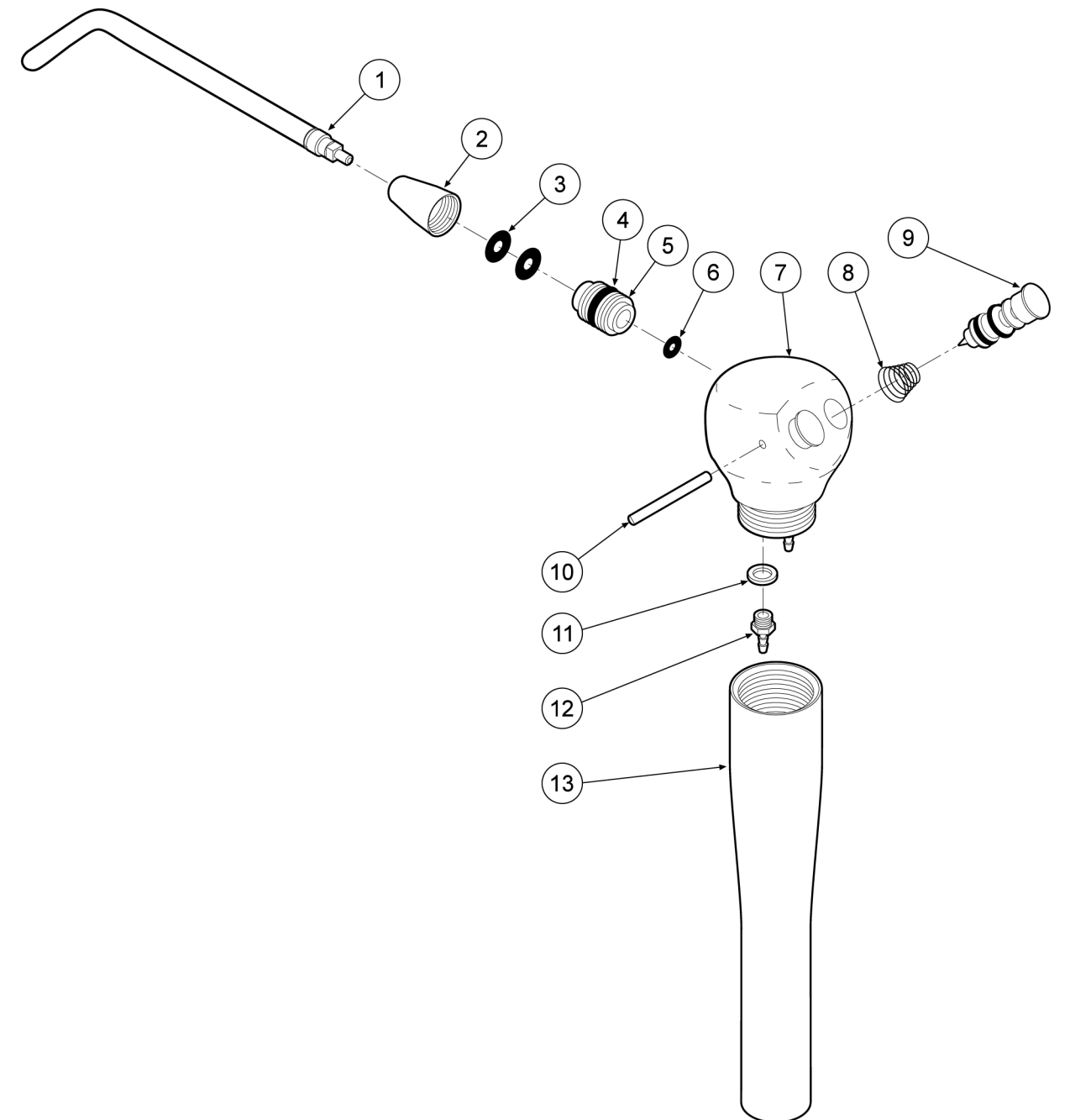

## Foot Control with Chip-Air Button

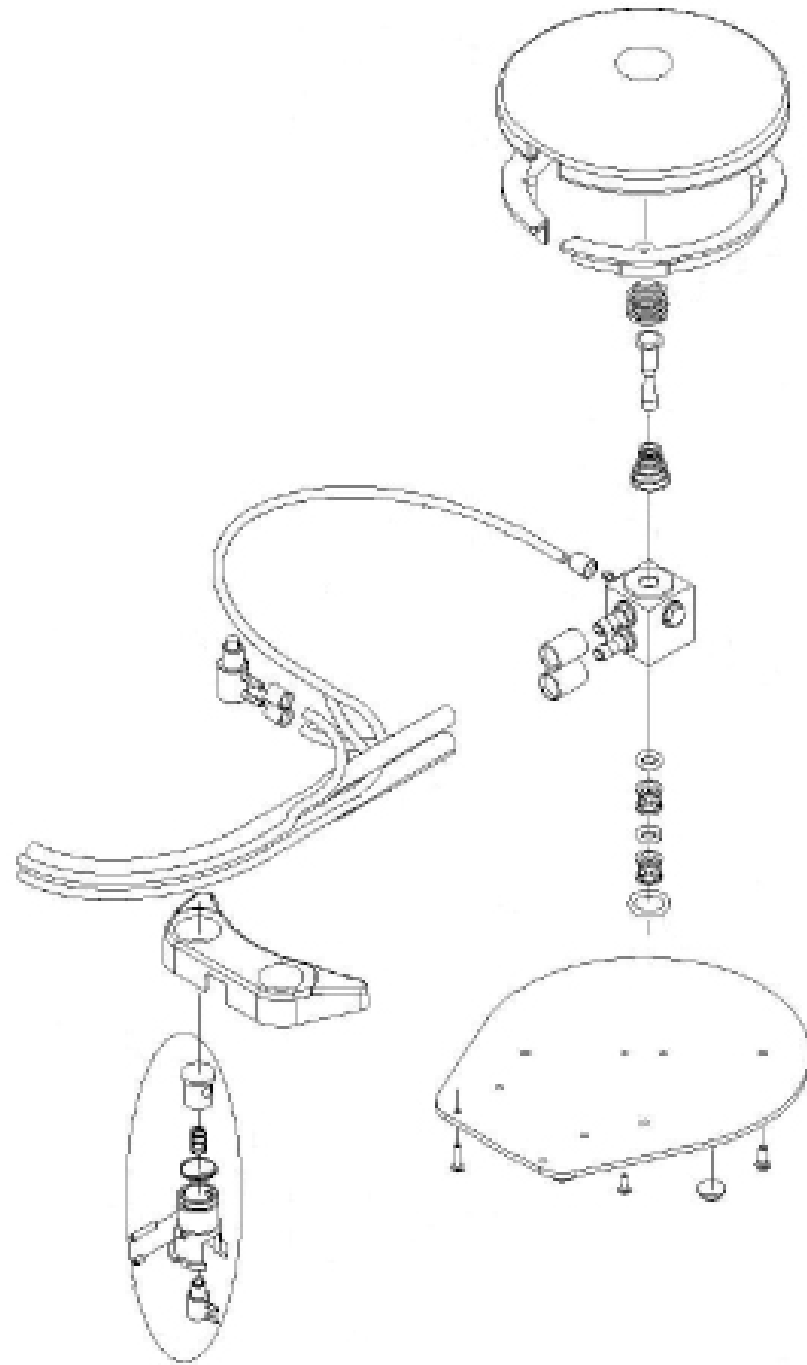

## WATER COOLANT

### *ADDING WATER TO DENTAL SYSTEM*

Slowly remove water bottle from pressure manifold assembly and add distilled water only. Leave approximately two inches of air space at the top. Replace bottle, tighten until secure. Mobile cart, wall mount and table mount systems hold 1500 ml. of water. Counter-top units hold 1000 ml. of water.

## AIR / WATER SYRINGE

All of our dental stations come with an air / water syringe installed and ready to use. Depress the left button for water only. Depress the right button for air only. Depress both buttons to get a mist spray.

## MAINTENANCE OF THE DENTALAIRE SYSTEMS

### *COMPRESSOR*

**Oil Change:** Please change the oil in the compressor once a year. To change the oil, you want to start by taking the compressor out of the Cart Frame, unplugging the black power cord and main Air line then remove the white cover off of the compressor by removing the six bolts at the bottom. Now tilt the compressor away from you and unscrew the site glass indicator. Tip the compressor forward and pour the oil into a small bucket or coffee can. Next screw the site glass back on. Put the white cover back over the compressor and screw in the six bolts.

Check us out on  YouTube



Please refer to our Compressor Maintenance Guide Chart below to help you keep the compressor running in top form.

### COMPRESSOR MAINTENANCE GUIDE CHART

Maintenance Procedure	Daily	Weekly	Monthly	Annually
Purge Drain	X			
Vent Moisture Trap		X		
Check Oil Level			X	
Clean Air Filter Intake				X
Change Oil				X
Complete Check of System				X

### SERVICE AND MAINTENANCE LOG

*Service Performed*

*Date*

*Serviced By*

1. Initial Installation

### AIR / WATER SYRINGE

Air or water leakage from the syringe is due to worn or damaged O-Rings on button assemblies. To rebuild syringe first remove the pin on the side of the head of the hand piece. Push the pin out of the syringe head with a small Allen wrench or something similar. Pushing down slightly on the buttons will help to remove the pin. Once the pin is removed, then simply pull the buttons straight out of the syringe head. Clean out the cylinders with a Q-tip. Re-install the Air/Water buttons. When inserting the buttons push the buttons down into the head of the handpiece and then let them rise slightly. The pin should push in with very little resistance. If too much resistance is felt make sure you are not pushing the pin into the O-rings on the buttons. Syringe Rebuild Kit Item # A113-403

### ORAL ILLUMINATION

This refers to the high-speed handpieces that has a fiber-optic system. This unit will periodically require a change in the Halogen Light Bulb. Here's how to change the bulb. (Note newer machines use LED bulbs that will not need replacement).

1. Please make sure you are wearing gloves (before) handling the new bulb. The oils from your hand will ruin the new halogen bulb.
2. Slide both sleeves back from the connector nut exposing the bulb on the side of housing.
3. Remove old bulb.
4. Install new bulb.
5. Place bulb back into housing
6. Slide sleeve over housing.
7. Reinstall high speed handpiece.

### Parts-List of the Series "SIL Air"

C0004	Clip for Terminal Bloc	C0110	Capacitor 230V 53-64 MFD T 2134	C0315	Cover T21
C0011	Filter Air Intake	C0111	Overload Protector 230V T 2134	C0316	Gasket to Cover T21
C0026	Gauge Pressure M1/8" 10 bar d=40mm	C0112	Relay Starting 230V T 2134	C0317	Overload Protector 115V T 2134
C0034	Strain Relief	C0113	Bolt	C0320	Bolt to Mount Stator T21
C0037	Bolt M6x20mm UNI 5931	C0114	Nut M8 UNI 5589	C0321	Stator 230V T21
C0039	Washer 5.3x10mm UNI 6592	C0115	Gasket Exhaust-Valve T 2134	C0322	Kit Motor-Parts 230V T2134 cpl. w/o Housing
C0040	Fitting Reduction M1/4"-F1/8"	C0116	Valve Plate cpl. T 2134	C0323	Valve Intake T 2134
C0043	Bolt TE M6x10mm DIN 934	C0117	Gasket Intake-Valve T 2134	C0324	Valve Exhaust T 2134
C0044	Handle Mod. 1080 135mm	C0120	Washer flat 8x24mm UNI 6593	C0325	Relay Starting 115V T 2134
C0045	Cable Electric 230V 600mm	C0124	Valve Safety 8 bar M1/4"	C0331	Kit Motor-Parts 115V cpl. T21
C0046	Valve Check M-F 1/8"	C0126	Foot Rubber	C0332	Stator 115V T21
C0047	Fitting M5 d=6mm	C0136	Frame / Support 50/15A	C0333	Kit Terminal-Bloc 115V T 2134
C0048	Switch Pressure 4-P 230V	C0137	Tank 15lt 50/15A	C0338	Capacitor 115V
C0049	Plug M 1/4"	C0138	Drain Cock M1/4"	C0339	Nylon Tube D8/6
C0051	Hose Nylon 6/4	C0144XX	Tank 50-9D	C0340	Switch Pressure 4-P 115V
C0061	Bolt M8x15mm	C0150	Fitting "L" M1/8"-F1/8"	C0349	Spring for Overload
C0062	Washer M10x20mm UNI 6592	C0151	Fitting Nipple M1/4"-M1/4" 60mm	C0354	Drain-Cock tanktop 15lt
C0063	Fitting "L" M1/4"-F1/8"	C0154	Washer Aluminum d=6mm 2x10	C0356	Tube Plastic 6/4 blue
C0064	Hose Air M1/8"xF1/4" 170mm	C0156	Fitting Manifold 4xF1/4"-1xF1/8"	C0357	Fitting "L" F1/8"-F1/8"
C0065	Fitting "L" rotating M1/4"x6.3mm	C0164	Filter Regulator WI	C0358	Oil-Level Indicator 1/2" Metal Frame
C0067	Bolt TE M8x35mm UNI 5739	C0164-1	Pressure Bowl WI	C0394XX	Tank 50-6
C0068	Power Cord 230V Euro-Plug	C0164-2	Filter Element WI	C0437XX	Tank 24lt 100/24 10CE D200
C0073	Hose Air M1/8"xF1/4" 235mm	C0164-4	Filter Regulator SMC	C0451	Cable Electric 115V 600mm
C0076	Fitting "L" M1/4"-F1/4"	C0164-5	Pressure Bowl SMC	C0458XX	Pump Compressor 115V T 2134
C0077	Fitting Swivel Connector M1/4"	C0164-6	Filter Element SMC	C0461XX	Housing 50-9D
C0081	Handle Rubber	C0164-7	Washer for Filter SMC	C0509	Fitting "L" M1/4"-F1/4"
C0082	Switch Pressure 1-P Condor	C0171	Kit for Grounding	C0516	Fitting Reduction M3/8"-F1/4"
C0083	Fitting M1/4" 80mm	C0180	Power Cord 115V American Plug	C0517	Plug Drain M 1"
C0088	Gauge Pressure 1/8" rear	C0200	Switch Pressure 1-P 230V	C0522	Washer 1"
C0089	Fitting M1/4"-M1/4" 95mm	C0202	Valve Head Pressure Release	C0567	Fitting Nipple M1/8"-M1/8"
C0091	Cable Electric 230V 500mm	C0205	Fitting Reduction M1/4"-F1/8"	C0583	Foot Rubber d=25mm
C0092	Fitting "T" M-F-F1/4"	C0222	Pump Compressor 230V T 2134	C0643	Valve Head Pressure Release
C0093	Cover for Terminal Bloc	C0272	Check Valve 100/24	C0659	Bolt TC M5x14mm
C0094	Foot Rubber	C0284	Pump Compressor 115V T 2134A	C0661	Nut M5 UNI 5567
C0097	Foot Rubber	C0286	Washer 8.5x15mm UNI 3703	C0895	Wheel Rubber d=80x25mm
C0099	Screw M6x20mm UNI 5739	C0305	Kit Terminal-Bloc 230V T 2134	C1094XX	Tank 24lt 50/24
C0100	Washer M8	C0306	Kit for Spring-Clamp	C1099	Oil-Level Indicator Plastic 1/2"
C0101	Closing Band	C0308	Kit Motor-Parts 230V cpl. T21	C1100	O-Ring 121
C0102	Cap Plastic Transparent	C0309	Bolt for Cover T21	C1235	Kit Valve Plate T 2134 cpl. with Gaskets
C0103	Gasket Housing	C0310	Pressure-Pipe T21	B0714	Bolt M8
C0105	Bolt M8x30mm	C0311	Gasket Pressure-Pipe T21	R0103	Spring Ring Outside
C0106	Spacer T 2134	C0312	Bolt to Top-Bearing	R0153	Bolt M8x25mm UNI 5739 ZN
C0108	Terminal-Bloc	C0313	Bearing Top T21		
C0109	Bracket for Capacitor	C0314	Spring for Suspension T21		

## DA400FOB - FIBER-OPTIC HALOGEN REPLACEMENT BULB

T2134A 230V - 50HZ  
115V - 60HZ

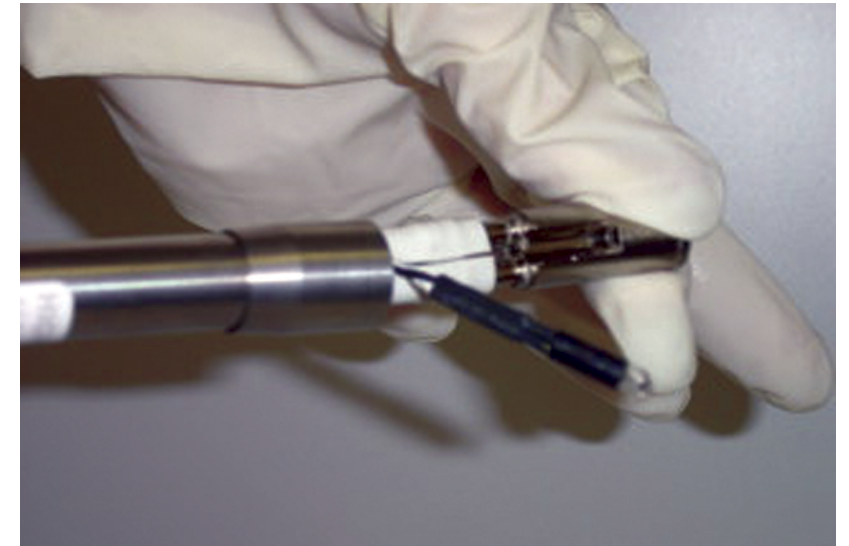
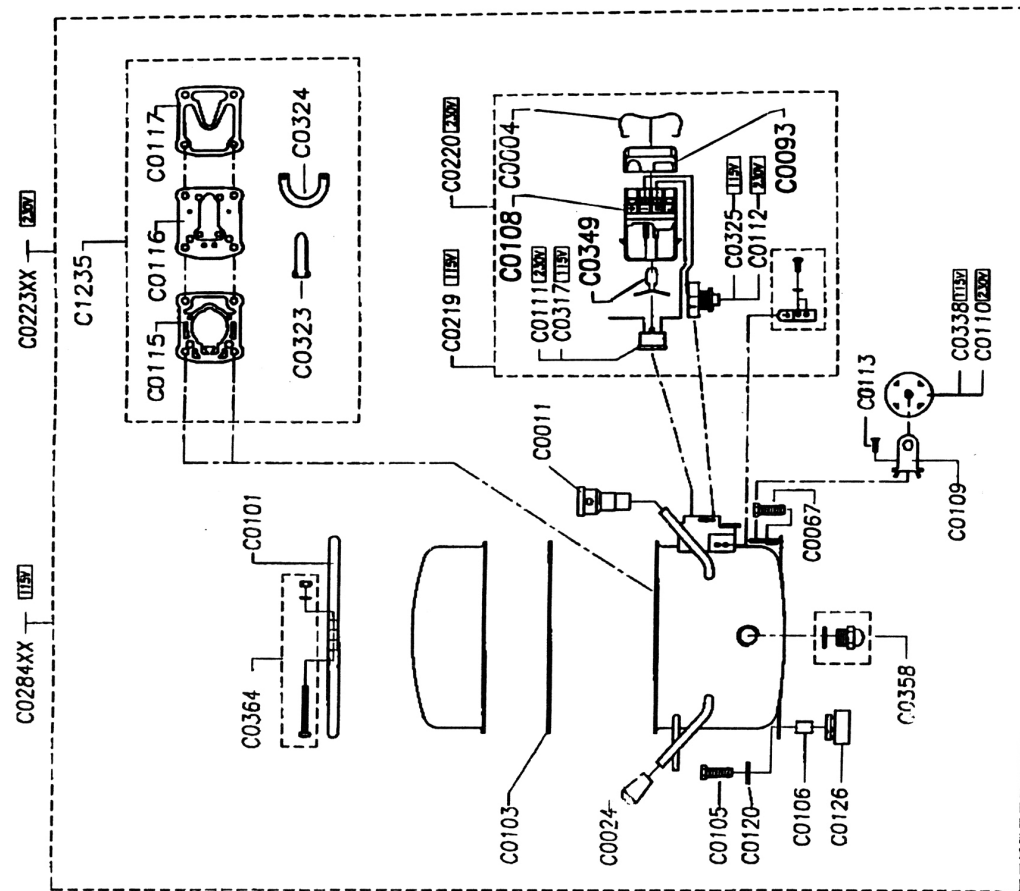

*Changing bulb on  
High-speed Handpiece*

## TROUBLE SHOOTING GUIDE

### *NO COOLANT WATER*

- Water bottle empty.
- Flow control knob is closed.
- On / Off toggle is off.
- High speed handpiece is in the low speed position
- Faulty water relay valve.
- Plugged coolant port in handpiece

### *COOLANT WATER DOES NOT SHUT OFF*

- Faulty water relay valve.
- Water On / Off toggle left on

### *COOLANT WATER LEAKING FROM HANDPIECE*

- Missing or damaged handpiece connector gasket.
- Faulty water relay valve.
- Slow speed handpiece is in the high speed position.

### *MORE THAN ONE HANDPIECE RUNS AT THE SAME TIME*

- Handpieces are not positioned all the way down in the holders.
- Faulty auto block diaphragm.

### *AIR / WATER SYRINGE PROBLEMS*

#### *Water drips from tip.*

- Faulty valve core

#### *Button blow out.*

- Tip is plugged at the end.

## SIL AIR 50-9 D

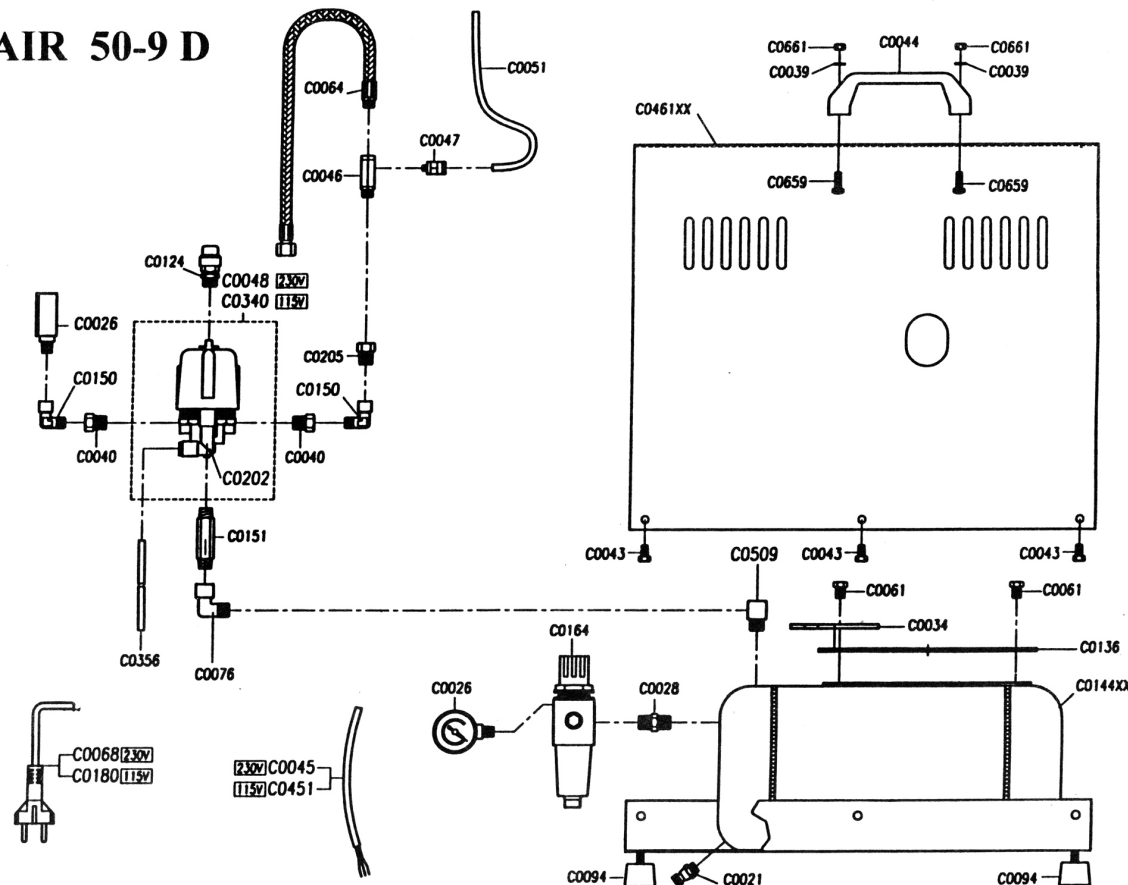



- b) Tip is not installed all the way into the into the Air Water Sprayer. (Loosen nut, press tip further into connector and tighten nut while holding the tip in)
  - c) Faulty o-ring in tip adapter.
3. Air or water leaks from buttons when in use.
- a) Faulty buttons.
4. Low air or water flow cont:
- a) Improper regulator adjustment
  - b) Empty water bottle
  - c) Kinked supply tubing.
  - d) Plugged tubing.
  - e) Plugged syringe head

#### *VI. FOOT CONTROL HISSES*

1. Faulty foot control popped valve.
2. Foot control tubing connected backwards.

#### *VII. HANDPIECE TUBING BLOWS OFF*

1. Handpiece has been over pressurized.

#### *VIII. COMPRESSOR WON'T TURN ON*

1. Check power source. Check tank pressure (compressor will not turn on if tank is fully pressurized).
3. Faulty starting capacitor (replace).
4. Compressor is over-heated and the thermal safety switch is off. (Let unit cool and it will come on automatically, usually in 20 - 30 minutes).

#### *IX. HANDPIECE LACKS POWER*

1. Inadequate tank pressure.
2. Improper regulator pressure (reset regulator).
3. Improper individual handpiece pressure adjustment.
4. Faulty foot control.
5. Handpiece connector gasket is missing.
6. Directional selector ring is not rotated all the way into forward or reverse. (Slow speed handpiece only)
7. Faulty handpiece tubing.

#### *X. COMPRESSOR RUNS, BUT WON'T PRESSURIZE FULLY*

1. Plug is on the air inlet. Replace with air filter.
2. Compressor tank drain valve is leaking air.
3. Faulty check valve between compressor and filter tank.

#### *XI. COMPRESSOR OVERHEATS*

1. Air inlet is plugged.
2. Handpiece pressure is set too high.

3. Handpiece has been run for too long a time and the 50% duty cycle has been exceeded.

#### *XII. UNIT IS PRESSURIZED BUT HANDPIECE DOES NOT RUN*

1. Regulator pressure is low or off.
2. Supply tubing from regulator to control head is kinked.
3. Faulty foot control.
4. Handpiece directional ring is between forward and reverse (slow speed handpiece only).
5. Faulty handpiece turbine.

### TROUBLE SHOOTING GUIDE FOR BUILT IN AMDENT PIEZO SCALER

#### *I. THE SCALER WON'T RUN*

1. Check main power , main fuse, On / Off Switch.

#### *II. WEAK OR NO TIP VIBRATION*

1. Increase the power control setting.
2. Check to see if tip is tightened properly.
3. The tip is worn out, replace with new tip.
4. Change to a new handpiece.
5. Faulty air switch.
6. Change back to the old handpiece and then replace the electronic part.
7. Replace both the handpiece and electronic part.

#### *III. INSUFFICIENT WATER SPRAY*

1. Turn the knob to full open position.
2. Check / replace water filter.
3. Check all water connections. Be sure there is no leakage or kinked tubing.
4. Remove the tip, if the water is dripping from the handpiece, replace the tip.
5. Check the delivery unit's control block that activates the water out to the scaler handpiece is working properly.

### FOOT CONTROL TO ULTRASONIC "PIEZO" SCALER

This foot pedal has two buttons, one large and one small. The large button is for operating the high and low speed handpieces. The small button is for operating the piezo scaler only.

